

## Filling Small Containers (Packets and Bottles)

### SCOPE

This control sheet is part of the ILO Chemical Control Toolkit and should be used when the toolkit identifies that a control approach 3 solution is needed. The sheet gives good practice advice on how to fill small packets or bottles. It describes the key points you have to follow to reduce exposure to an adequate level. It is important that all the points are followed. Some chemicals are flammable or corrosive and your controls must be suitable for those hazards too. Look at the safety data sheet for more information. This sheet identifies the minimum standards you need to apply to protect your health. It should not be used to justify a lower standard of control than that which may be required for process control or control of other risks.

### ACCESS

- Keep unnecessary people away from the work area. Ensure that no one is working close by downwind.

### DESIGN AND EQUIPMENT

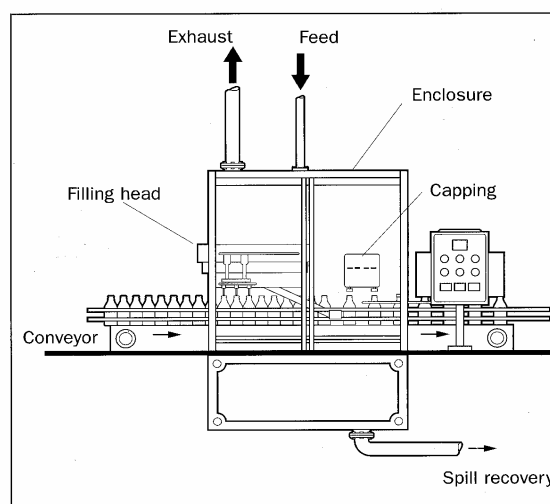
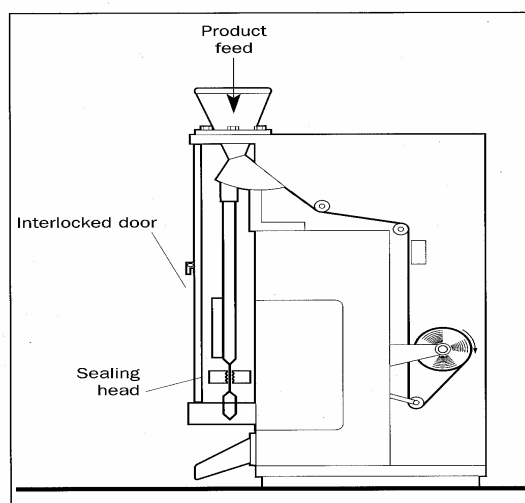

- Enclose the feed transfer system as fully as possible and provide an enclosure around the filling heads.
- Integrate the weighing/volume measurement to minimise open transfer.
- Design the enclosure to ensure that any high-velocity air jets from pneumatic system discharges do not breach the containment.
- Design the enclosure for easy access for cleaning and maintenance. Food product packaging in particular will require regular access for cleaning.
- Provide a spillage containment/removal system.
- Provide flexible curtains at the open ends of the enclosures, e.g. on transfer conveyors.
- Keep the process under negative pressure to prevent leakage, inward airflow should be at least 1 metre/second for dusts and 0.5 metres/second for vapours.

- Discharge extracted air to a safe place away from doors, windows and air inlets.
- Consider the need for inert atmospheres or explosion relief.

## **EXAMINATION, TESTING AND MAINTENANCE**

- Ensure all equipment used is maintained in good repair and efficient working order. Have the system thoroughly examined and tested at least once a year.
- Check that the extraction system is working every day when it is switched on.
- Visually check the ducting once a week for signs of damage, and repair when necessary.
- Adopt a “permit-to-work” system for all maintenance work – see sheet S101.
- Document and follow any special procedures that are needed before the system is opened or entered, e.g. purging or washing.
- Don't enter any vessel until it is safe to do so. Check for hazardous or flammable substances and sufficient oxygen (between 19.5% and 22%). Note that entry or the work may give rise to a hazardous situation, e. g. disturbing sludge, welding may deplete oxygen.
- Check all the equipment once a week for signs of damage and repair when necessary.

## **CLEANING AND HOUSEKEEPING**

- Clean the work equipment and work area daily.
- Spills are the major cause of dust or vapour in the workplace. Clean up all spills immediately.
- Don't clean up dusts with a brush or compressed air. Use a damp cloth or vacuum.
- Put lids on containers immediately after use.
- Store containers in a safe place where they won't get damaged.
- Store volatile liquids out of direct sunlight.

## **PERSONAL PROTECTIVE EQUIPMENT (PPE)**

- Chemicals in hazard group S can damage the skin or eyes, or enter the body through the skin and harm you. Sheets Sk100 and Sk101 give good advice on how to keep the materials off your skin.
- Check the material safety data sheet or ask your supplier to find out what personal protective equipment is needed.
- Respiratory protective equipment (RPE) should not be needed for routine tasks, but may be necessary for cleaning and maintenance activities and when dealing with spills.
- Be aware that some maintenance tasks may involve entry into confined spaces where supplied air RPE may be needed when there is not enough pure air to breathe.
- Look after your protective equipment. When not in use, keep it clean and store it in a clean, safe place.
- Keep your protective equipment clean and change it at recommended intervals or when it is damaged.

## **TRAINING AND SUPERVISION**

- Tell your workers about any harmful properties of the substances they are working with and why they must use the controls and PPE provided.

- ➡ Teach them to handle chemicals safely. Check controls are working and ensure that they know what to do if something goes wrong.
- ➡ Have a system to check that the precautions you have put in place are being followed.